

EZ Scooter Rack 10 Berth

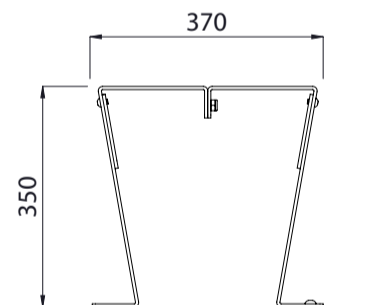

Colours / finishes shown are indicative only and may differ in reality.

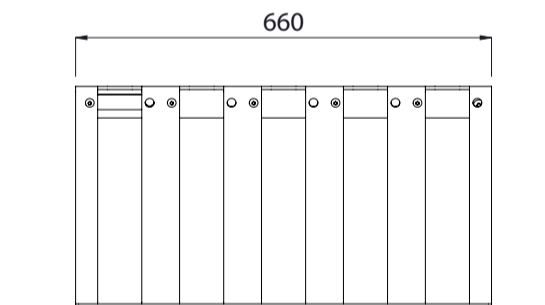
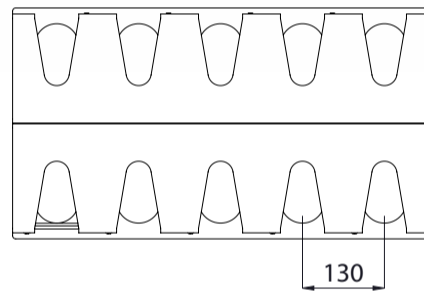

	MATERIALS	FINISHES	FINISH OPTIONS
Steelwork	<ul style="list-style-type: none"> Mild Steel Aluminium 304 Stainless steel 	<ul style="list-style-type: none"> Hot dip galvanised only or Hot dip galvanised and Powdercoated Powdercoated as standard Electropolished as standard 	<ul style="list-style-type: none"> Custom paint options
Hardware / Fasteners	<ul style="list-style-type: none"> Stainless steel 		
	OPTIONS	DIMENSIONS	WEIGHT
	<ul style="list-style-type: none"> Surface mounted Hinged locking tabs as standard Padlocks <u>not</u> supplied as standard 	<ul style="list-style-type: none"> 660L x 350H x 370D 	<ul style="list-style-type: none"> 8Kg (Aluminium) 20Kg (Steel)

- Made to order and can be customised to suit clients requirements.
- Furniture is not supplied with installation instructions, install fastenings or footing details. These are to be specified and determined by the installing contractor for the specific requirements of each site.