

Waihi Bench AC 1800mm Long

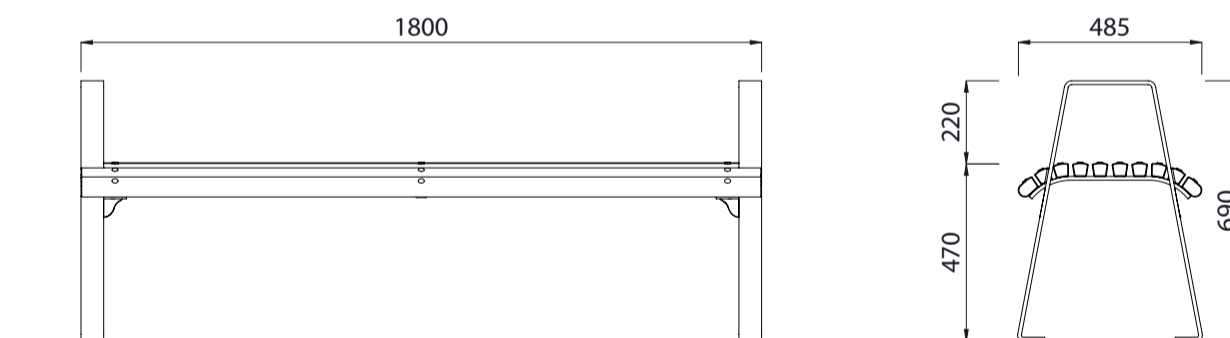

Meets Accessibility Standards NZS4121-2001.
Colours / finishes shown are indicative only and may differ in reality.

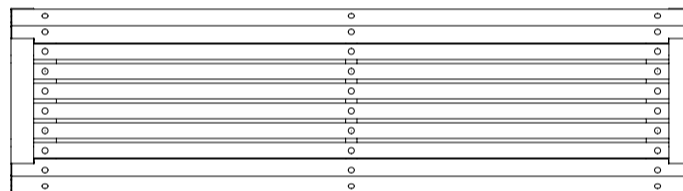

MATERIALS

- Timber (Hardwood)**
 - Vitex as standard
 - Other species available on request
- Steelwork**
 - Mild steel
- Hardware / Fasteners**
 - Stainless steel with brass cap nuts

FINISHES

- Un-sealed (Natural) as standard
- Hot dip galvanised and **powdercoated** as standard

FINISH OPTIONS

- Penetrating oil / Graffiti guard / Clear sealant
- Custom paint options

OPTIONS

- Plant mounted with inserts or surface mounted
- Armrests to both ends as standard
- [Skate deterrents](#)

DIMENSIONS

- 1800L x 690H x 485D as standard

WEIGHT

- 44Kg

- Made to order and can be customised to suit clients requirements.
- Furniture is not supplied with installation instructions, install fastenings or footing details. These are to be specified and determined by the installing contractor for the specific requirements of each site.