

Queenstown Single 120L Wheelie Bin Enclosure

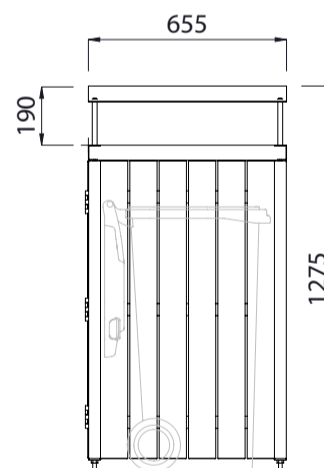

Colours / finishes shown are indicative only and may differ in reality.

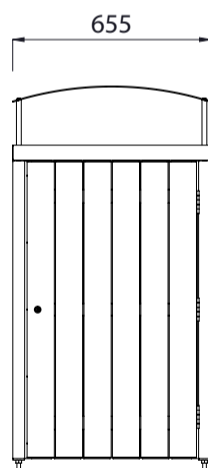
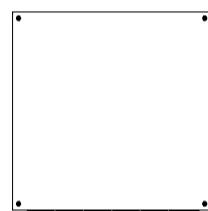

MATERIALS

- Timber (Hardwood)**
 - Vitex as standard
 - Other species available on request
- Steelwork**
 - Mild steel as standard
 - Stainless steel (coastal)
- Hardware / Fasteners**
 - Stainless steel

OPTIONS

- Surface mounted with adjustable feet as standard
- Modular design allows for custom unit quantities
- Powdercoated decal panel

FINISHES

- Un-sealed (Natural) as standard
- Electro-plated and **powdercoated**
- **Powdercoated** as standard

DIMENSIONS

- 655L x 1275H x 655D (Single unit)
- 1310L x 1275H x 655D (Double unit)
- 1965L x 1275H x 655D (Triple unit)

FINISH OPTIONS

- Penetrating oil / Graffiti guard / Clear sealant
- Graffiti guard

WEIGHT

- 65Kg
- 130Kg
- 195Kg

- Wheelie bin not supplied with unit.
- Made to order and can be customised to suit clients requirements.
- Furniture is not supplied with installation instructions, install fastenings or footing details. These are to be specified and determined by the installing contractor for the specific requirements of each site.

Queenstown Suite Complementing Bins



Queenstown 120L Single



Queenstown 240L Single



Queenstown 120L Double



Queenstown 240L Double



Queenstown 120L Triple



Queenstown 240L Triple