

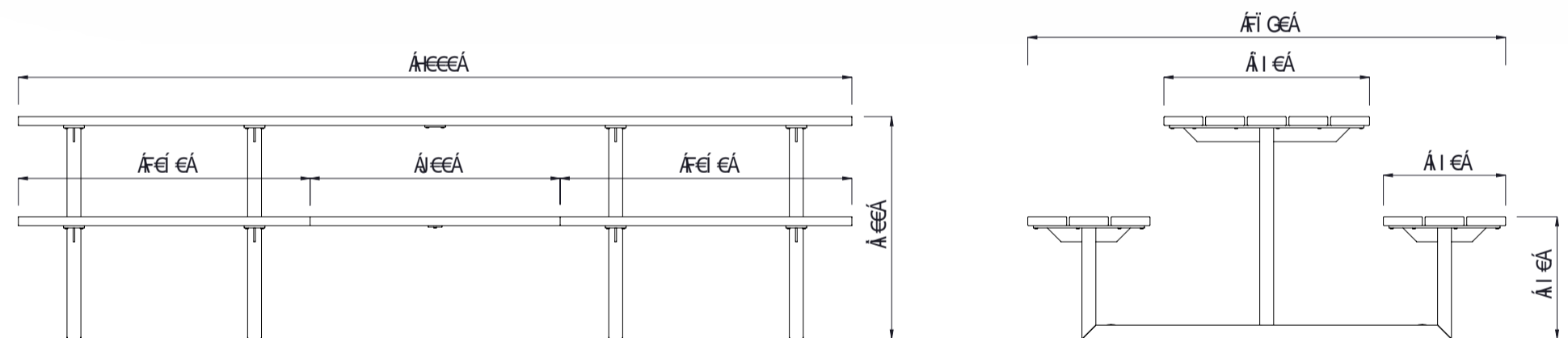

T ^ ^ c Á Ú æ } æ Á Ú ^ c Á Ó É  
Ô [ [ \ ! Á Ú æ } æ Á Ú ^ c Á Ó É ] Á Ú æ } æ Á Ú ^ c Á Ó É



MATERIALS	FINISHES	FINISH OPTIONS
<p><b>Timber (Hardwood)</b></p> <ul style="list-style-type: none"> <li>Vitex as standard</li> <li>Other species available on request</li> </ul>	<ul style="list-style-type: none"> <li>Un-sealed (Natural) as standard</li> <li>Hot dip galvanised and <b>powdercoated</b></li> </ul>	<ul style="list-style-type: none"> <li>Penetrating oil / Graffiti guard / Clear sealant</li> <li>Custom paint options</li> </ul>
<p><b>Steelwork</b></p> <ul style="list-style-type: none"> <li>Mild steel as standard</li> </ul>		
<p><b>Hardware / Fasteners</b></p> <ul style="list-style-type: none"> <li>Stainless steel</li> </ul>		
OPTIONS	DIMENSIONS	WEIGHT
<ul style="list-style-type: none"> <li>Plant mounted with inserts, surface mounted or freestanding</li> <li>Wheelchair access to one or both sides</li> <li>Umbrella hole</li> </ul>	<ul style="list-style-type: none"> <li>3000L x 800H x 1720D as standard</li> </ul>	<ul style="list-style-type: none"> <li>190Kg</li> </ul>
<ul style="list-style-type: none"> <li>Made to order and can be customised to suit clients requirements.</li> <li>Furniture is not supplied with installation instructions, install fastenings or footing details. These are to be specified and determined by the installing contractor for the specific requirements of each site.</li> </ul>		