

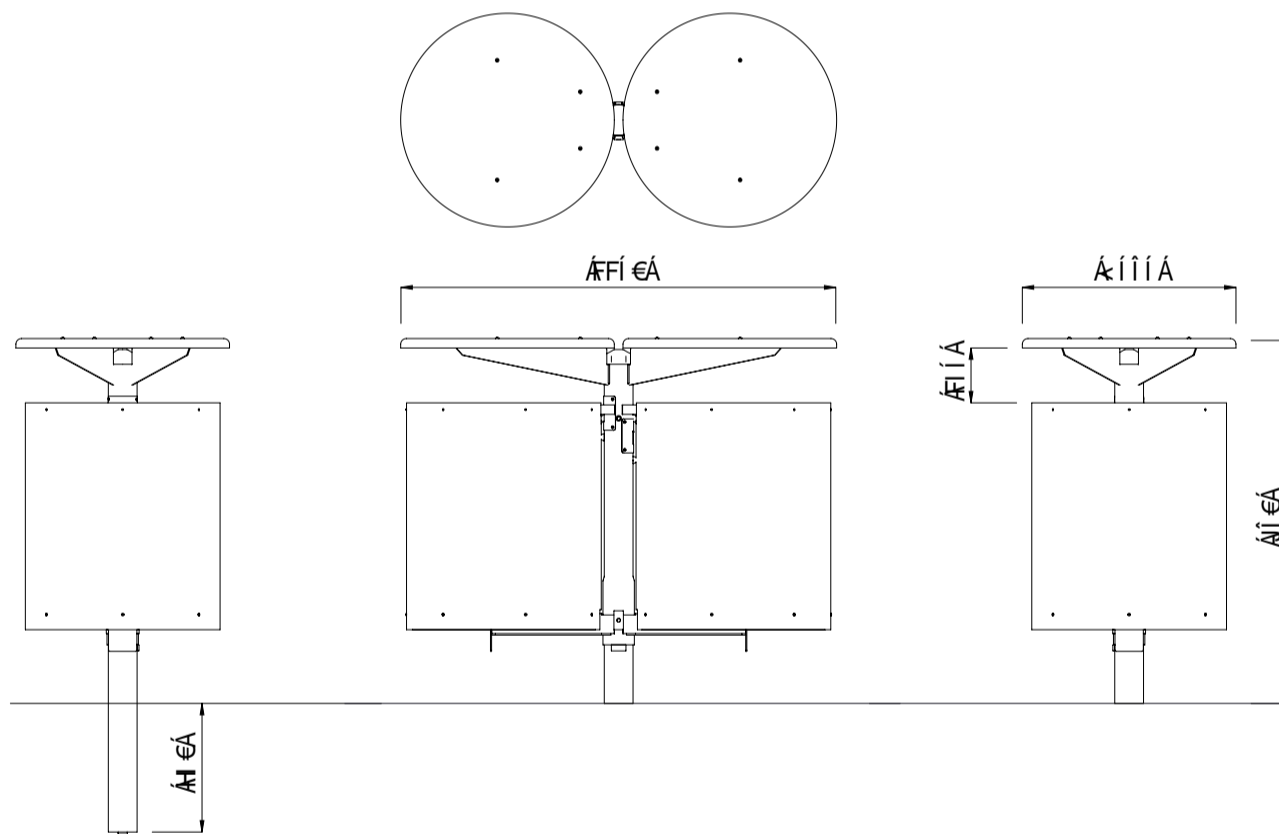

Ö[|^|~|•Ääã@•Ä@, }Äe^Ä ääçç^Ä }|^Ä äÄ æÄä-!Ä Ä^çÄ Ä



MATERIALS

Steelwork

- Stainless steel 304 or 316 grade
- Mild steel
- Galvanised liners as standard - 100L
- Mild steel mounting base

Hardware / Fasteners

- Stainless steel

FINISHES

- Electropolished as standard
- Powdercoated as standard
- Hot dip galvanised as standard

FINISH OPTIONS

- Electropolished lid and wrap
- Galvanised post
- Powdercoated lid and wrap,
- Galvanised post

OPTIONS

- Plant mounted as standard
- Single or Double units
- Laser cut logo / design

DIMENSIONS

- Ø565 x 960H x 1150W

WEIGHT

- 69Kg

- Part of the 'Tilt Bin' range. Made to order and can be customised to suit clients requirements.
- Furniture is not supplied with installation instructions, install fastenings or footing details. These are to be specified and determined by the installing contractor for the specific requirements of each site.



Üi €! ÁÜFEEÁãÓã Á çããã à! ÁU|æ



Üi €! ÁÜFEEÁãÓã Á çããã à! ÁU|æ



Üi €! ÁÜFEEÖ[~ à! ÁããÓã Á çããã à! ÁU|æ



Üi €! ÁÜFEEÖ[~ à! ÁããÓã Á çããã à! ÁU|æ



VãããÖ[~ { Á Áããããã! ~ { Áããããã { Á[çããã à! áãD



VãããÖ[~ { Á Áããããã! ~ { Áããããã { Á[çããã à! áãD