

Ô[ | ~ | • Áã @ • Á @ , } Á^ Á áãæ^ Á } | Á á Á æ Áã-! Á Á æ Á

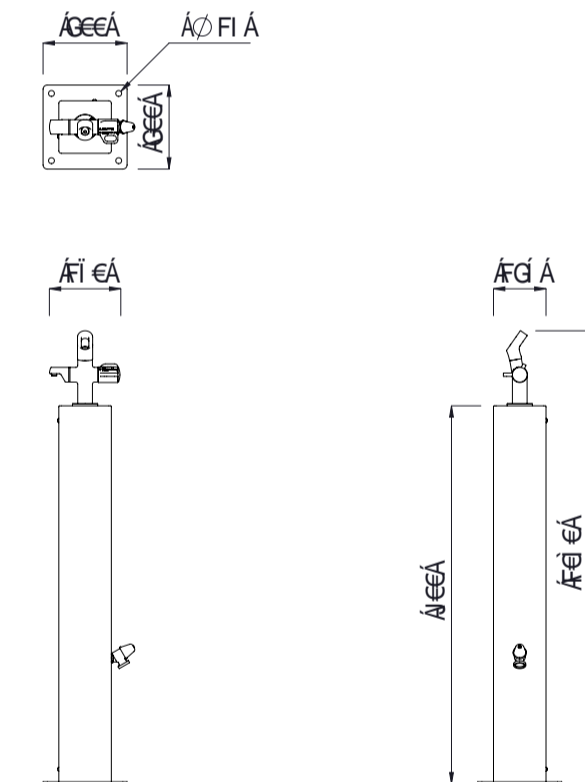

**MATERIALS**

- Metalwork**
  - Aluminium as standard
- Bubbler**
  - DR Brass
- Hardware / Fasteners**
  - Stainless steel

**FINISHES**

- Powdercoated as standard
- Chrome plated with rubber mouth guard

**FINISH OPTIONS**

- Custom paint options

**OPTIONS**

- Brass Hose Tap - Supplied loose to be plumbed by installer
- Bubbler options with or without bottle filler

**DIMENSIONS**

- 170W x 1080H x 125D (Surface Mounted)

**WEIGHT**

- 8Kg

- Part of the 'Waipuna' fountain range. Made to order and can be customised to suit clients requirements.
  - **Plumbing not included - to be specified/supplied and completed by a qualified installer.**
  - **Pressure reducers and/or back flow preventers to be added at the installers discretion.**
- Furniture is not supplied with installation instructions, install fastenings or footing details. These are to be specified and determined by the installing contractor for the specific requirements of each site.