

# Plaza Cycle Stand 450W

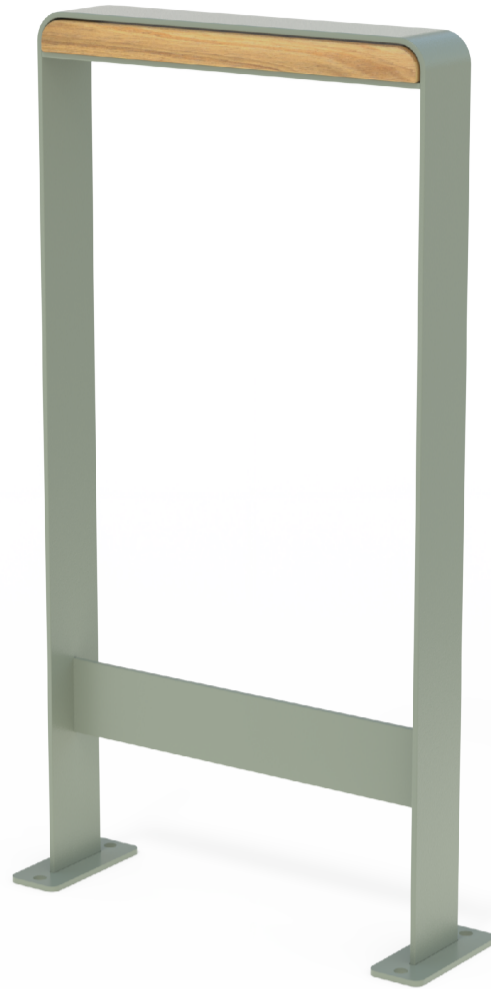

Colours / finishes shown are indicative only and may differ in reality.

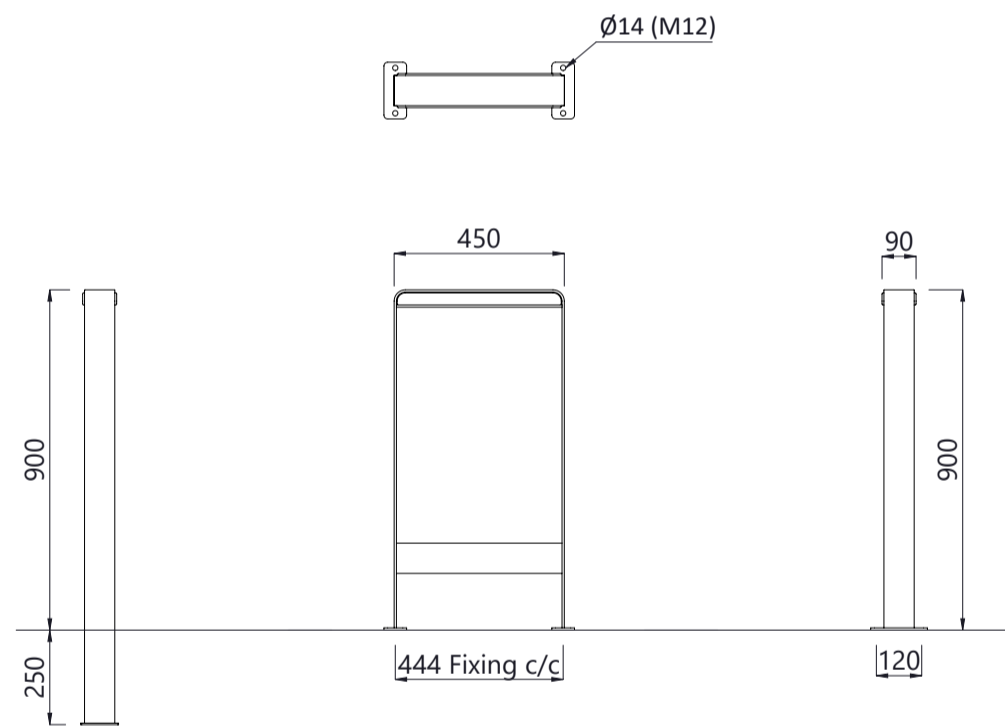

	<b>MATERIALS</b>	<b>FINISHES</b>	<b>FINISH OPTIONS</b>
<b>Timber (Hardwood)</b>	<ul style="list-style-type: none"> <li>Vitex as standard</li> <li>Other species available on request</li> </ul>	<ul style="list-style-type: none"> <li>Un-sealed (Natural) as standard</li> </ul>	<ul style="list-style-type: none"> <li>Penetrating oil / Graffiti guard</li> </ul>
<b>Metalwork</b>	<ul style="list-style-type: none"> <li>Aluminium as standard</li> </ul>	<ul style="list-style-type: none"> <li>Powdercoated</li> </ul>	<ul style="list-style-type: none"> <li>Custom paint options</li> </ul>
<b>Hardware / Fasteners</b>	<ul style="list-style-type: none"> <li>Stainless steel</li> </ul>		
	<b>OPTIONS</b>	<b>DIMENSIONS</b>	<b>WEIGHT</b>
		<ul style="list-style-type: none"> <li>450L x 900H x 90D as standard</li> </ul>	<ul style="list-style-type: none"> <li>5 Kg</li> </ul>

- MOUNT TYPE**
- Surface mounted - TYPE B1
  - Plant mounted - TYPE E

(Refer to Footing Detail Sheet for mount type)

- Part of the 'Plaza' furniture suite. Made to order and can be customised to suit clients requirements.
- Furniture is not supplied with installation instructions, install fastenings or footing details. These are to be specified and determined by the installing contractor for the specific requirements of each site.